

# Air Preparation Equipment

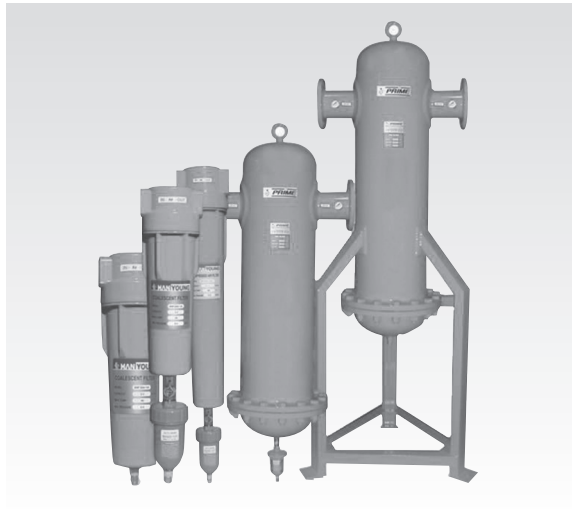



---

- Air Filter  
Series TXF ..... 1008
- Air Dryer  
Series TAD ..... 1015

---

※ Specifications in this catalogue may be changed for product performance upgrade without notice.  
Inquiries can be made to the manufacturer when purchasing the product.

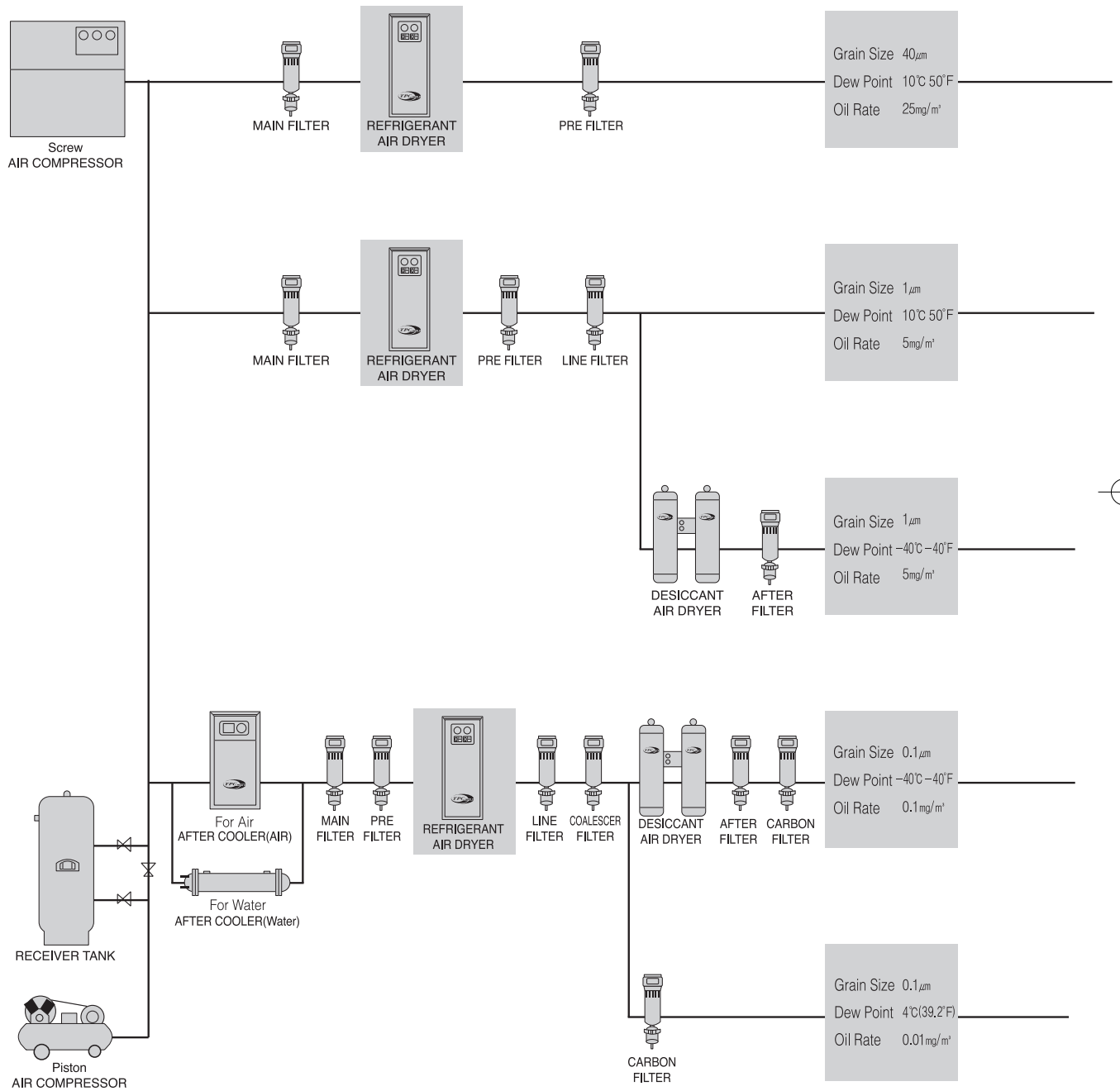
# Applied Industry Fields / Application Areas—Main Line Air Treatment



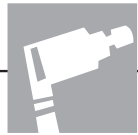

Service Air

- Air Tools



Mining Industry

- Air Tools
- Breathable Air

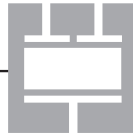

Service Air

- Control System
- Forging Facilities
- Blowing System
- Conveyor System



Electric Power Industry

- Gas Turbine & Gas Booster
- Control System
- Emergency Generator
- Gas Booster

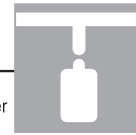

Glass & PET Manufacture

- Control System
- Conveyor System
- Bottle Manufacture

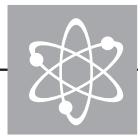

Nuclear Power Industry

- Emergency Generator
- Control System
- Generator Cooling
- Service Air



Paper & Fabric Industry

- Control System
- Conveyor System
- Service Air



Machinery

- Automation System
- Service Air



Gas Industry

- Liquefaction
- Preservation
- Boosting



Painting Industry

- Painting
- Cleaning
- Service Air



Air Supply Instrumentation

- Engine Starting System
- Service Air



Heavy Industry

- Control System
- Engine Starting System
- Service Air



Petrochemical Industry

- Refinery
- Transmissions
- Processing

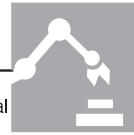

Automation Industry

- Control System
- Operating System

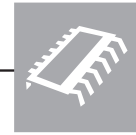

Electronic Industry

- Control System
- Heat Treatment System
- Coating System



Pharmacy Industry

- Control System
- Conveyor, Mixing System
- Dentist's Air Tools
- Breathable Air



Chemical Industry

- Control System
- Chemical Reaction
- Conveyor System
- Service Air

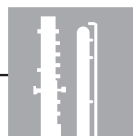

Air-Liquefaction Separation

- Turn Key Engineering

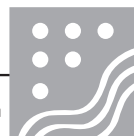

Powder & Liquid Mixing

- Anti-Oxidation System
- Mixing System
- Transmissions



Food Industry

- Packing
- Storing
- Fermentation
- Carbon Dioxide
- Refrigeration

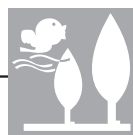

Environment Industry

- Ozon Generator
- Wastewater Treatment
- Incineration Plant
- Dust Collection Plant
- Desulfurization Plant

# Series **TXF 15A ~ 300A**

## High Performance Air Filter



### HIGH PERFORMANCE AIR FILTER

- REMOVE THE GREAT HAZARDOUS SUBSTANCE IN COMPRESSED AIR.

### High-performance elements protecting expensive high-tech equipment display an excellent performance in removing the fine pollutants in compressed air.

This filter is installed on the main pipe to remove foreign substances such as oil, moisture, and dust in the compressed air, to provide clean air, and to prevent failures due to those foreign substances in devices at the back part.

The compressed air flowed into the filter body passes through the outside (inside) of the filter elements located in the center. During this process, foreign substances in the air are filtered, while clean air is provided to each device. After passing through the filter, oil, moisture, and dust flow down the surface of the elements, and are collected at the bottom of the filter, while solid matter is discharged through the Auto Drain Trap to the outside.

This air filter displays its maximum performance in both cost and efficiency only when right filters for applications (e.g. particulate filter for particle removal, and coalescing filter for oil removal) are used.

## How to Order

**TXF** — **15A** — **370**

1                      2                      3

1 High Performance Air Filter (TXF)

2 Element Size (TXE)  
: See the Specifications Table

3 Attachment

Filtration  
370 : 20  $\mu$ m  
320 : 3  $\mu$ m  
310 : 1  $\mu$ m  
130 : 0.01  $\mu$ m  
150 : 0.01 ppm

# Series TXF

## Air Filter

TXF  
TAD

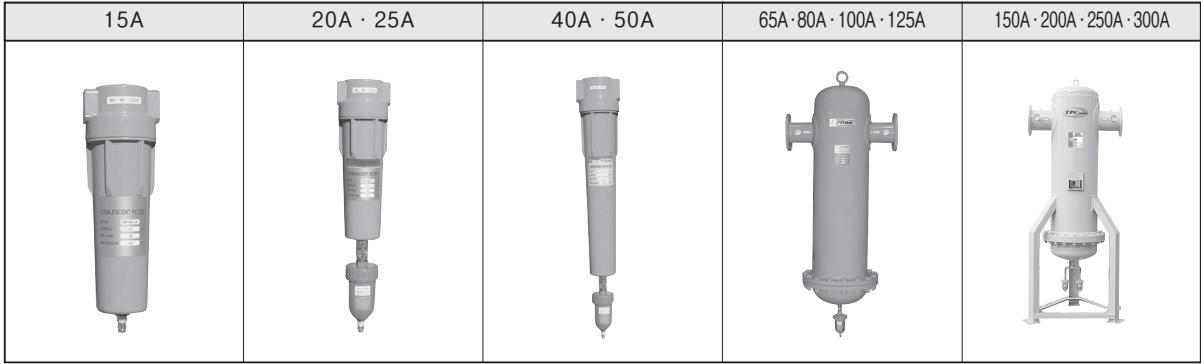

## Specification

Filter Type Model		CAPACITY(Nm <sup>3</sup> /min)				
		Main Filter	Pre Filter	Line Filter	Coalescent Filter	Absorbent Filter
		370(20 $\mu$ m)	320(3 $\mu$ m)	310(1 $\mu$ m)	130(0.01 $\mu$ m)	150(0.01ppm)
TXF-15A	1/2" (S)	2.2	1.8	1.2	1.0	1.0
TXF-20A	3/4" (S)	5.7	3.5	2.8	1.9	1.9
TXF-25A	1" (S)	8.0	5.7	5.0	3.4	3.4
TXF-40A	1 1/2" (S)	17.0	14.0	11.0	10.0	10.0
TXF-50A	2" (S)	29.0	25.0	22.0	14.0	14.0
TXF-65A	2 1/2" (F)	58.0	50.0	48.0	28.0	28.0
TXF-80A	3" (F)	88.0	75.0	72.0	42.0	42.0
TXF-100A	4" (F)	145.0	125.0	110.0	70.0	70.0
TXF-125A	5" (F)	174.0	150.0	132.0	84.0	84.0
TXF-150A	6" (F)	282.0	221.0	176.0	112.0	112.0
TXF-200A	8" (F)	447.0	331.0	308.0	196.0	196.0
TXF-250A	10" (F)	733.0	555.0	528.0	336.0	336.0
TXF-300A	12" (F)	1103.0	850.0	792.0	504.0	504.0

\* S: Socket, F: Flange \* TXF-65A or higher are produced to order. \* The above products may be changed without prior notice.

## Dimension

Model	Width	Height	Weight
TXF-15A	88	278	1.25
TXF-20A	89	500	2.5
TXF-25A	100	600	4.5
TXF-40A	138	835	13.7
TXF-50A	148	910	21
TXF-65A	492	1134	85
TXF-80A	492	1134	95
TXF-100A	620	1305	125
TXF-125A	620	1305	140
TXF-150A	812	2060	250
TXF-200A	1000	2425	340
TXF-250A	1200	2270	400
TXF-300A	1450	2620	450

## Element Q' TY

Model	370	320	310	130	150
TXE-15A			1		
TXE-20A			1		
TXE-25A			1		
TXE-40A			1		
TXE-50A			1		
TXE-65A			2		
TXE-80A			3		
TXE-100A			5		
TXE-125A			6		
TXE-150A			11		
TXE-200A			14		
TXE-250A			24		
TXE-300A			36		

# Series **TXF**





## Elements



### FEATURES

- SINCE HOUSING IS ONE-TOUCH CLAMP TYPE PROVIDING DIRECT FIXING OF ELEMENTS, IT IS EASY AND CONVENIENT TO EXCHANGE ELEMENTS.
- THESE HAVE THE ELEMENTS OF MEDIA NECESSARY FOR THE REMOVAL OF OIL, MOISTURE, AND SPECIAL GASES AS WELL AS FINE PARTICLES.

### SPECIFICATIONS

<p><b>MAIN</b> TXE-370</p> 	<p>Filtration : 20<math>\mu</math>m Use : Remove 20 <math>\mu</math>m or larger particles of liquid water, oil, rust, and sediments.</p>
<p><b>PRE</b> TXE-320</p> 	<p>Filtration : 3<math>\mu</math>m Use : Remove 3 <math>\mu</math>m or larger particles of liquid water, oil, rust, and sediments, and is generally used the most.</p>
<p><b>LINE</b> TXE-310</p> 	<p>Filtration : 1<math>\mu</math>m Use : Used for tools for cutting, and for general air tools.</p>
<p><b>COALESCENT</b> TXE-130</p> 	<p>Filtration : 0.01<math>\mu</math>m Use : Remove spray paint and oil mist up to 99 %, but cannot remove the smell.</p>
<p><b>ADSORBENT</b> TXE-150</p> 	<p>Filtration : 0.01PPM Use : Element with oil mist removal function upgraded. Used for the production process of precision electronics, semiconductor, and pharmaceutical products.</p>

Model	370, 320, 310, 130, 150
TXF-15A	1
TXF-20A	1
TXF-25A	1
TXF-40A	1
TXF-50A	1
TXF-65A	2
TXF-80A	3
TXF-100A	5
TXF-125A	6
TXF-150A	11
TXF-200A	14
TXF-250A	24
TXF-300A	36

### DIMENSION

SIZE	15A	20A	25A	40A	50A
(mm)	48×105	48×151	48×200	68×450	78×460

# Series TXF

## Outside Views of TXF 15A-370, 320, 310, 130, and 150

TXF

TAD

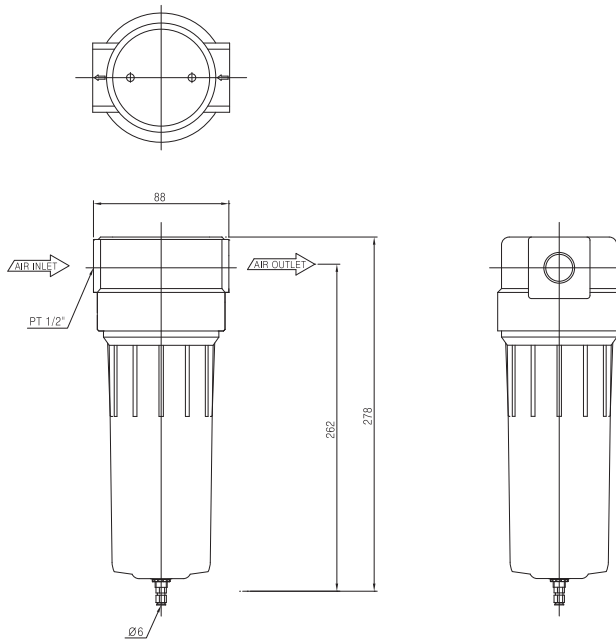

Model	CAPACITY(Nm <sup>3</sup> /min)	FILTER ELEMENT
370	2.2	MAIN ELEMENT(20u)
320	1.8	PRE ELEMENT(3u)
310	1.2	LINE ELEMENT(1u)
130	1.0	COALESCENT ELEMENT(0.01u)
150	1.0	ADSORBENT ELEMENT(0.01ppm)

## Outside Views of TXF 20A-370, 320, 310, 130, and 150

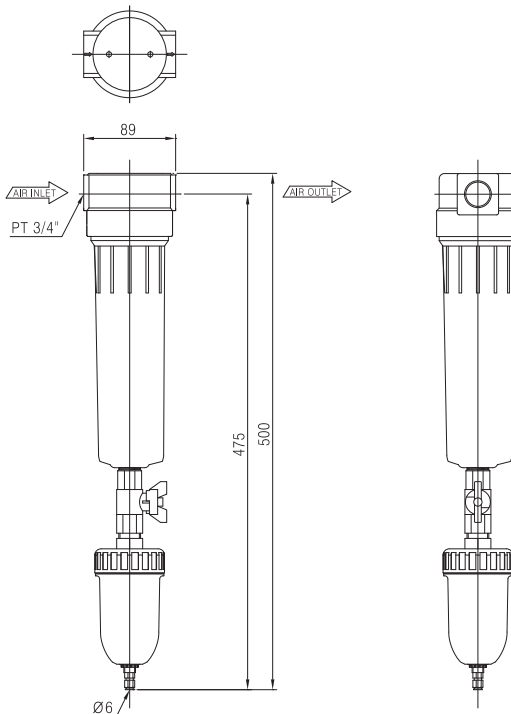

Model	CAPACITY(Nm <sup>3</sup> /min)	FILTER ELEMENT
370	5.7	MAIN ELEMENT(20u)
320	3.5	PRE ELEMENT(3u)
310	2.8	LINE ELEMENT(1u)
130	1.9	COALESCENT ELEMENT(0.01u)
150	1.9	COALESCENT ELEMENT(0.01ppm)



## Series TXF

### Outside Views of TXF 25A-370, 320, 310, 130, and 150

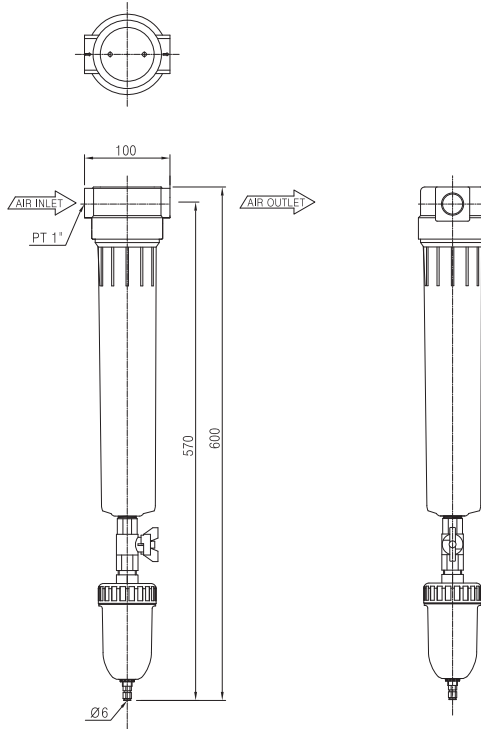

Model	CAPACITY(Nm <sup>3</sup> /min)	FILTER ELEMENT
370	8.0	MAIN ELEMENT(20u)
320	5.7	PRE ELEMENT(3u)
310	5.0	LINE ELEMENT(1u)
130	3.4	COALESCENT ELEMENT(0.01u)
150	3.4	COALESCENT ELEMENT(0.01ppm)

### Outside Views of TXF 40A-370, 320, 310, 130, and 150

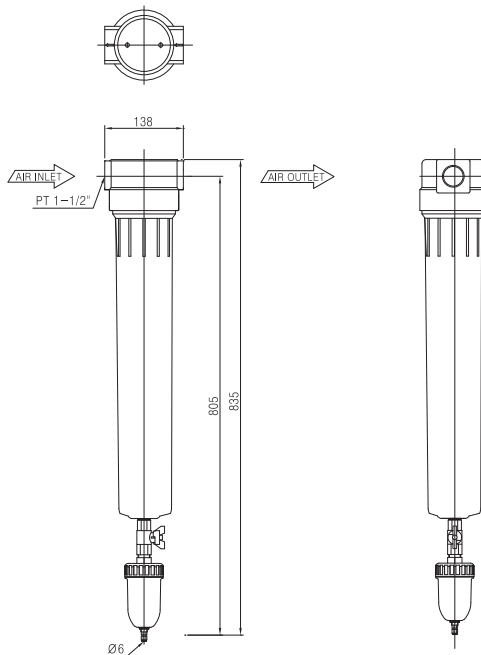

Model	CAPACITY(Nm <sup>3</sup> /min)	FILTER ELEMENT
370	17	MAIN ELEMENT(20u)
320	14	PRE ELEMENT(3u)
310	11	LINE ELEMENT(1u)
130	10	COALESCENT ELEMENT(0.01u)
150	10	ADSORBENT ELEMENT(0.01ppm)

# Series TXF

## Outside Views of TXF 50A-370, 320, 310, 130, and 150

**TXF**  
**TAD**

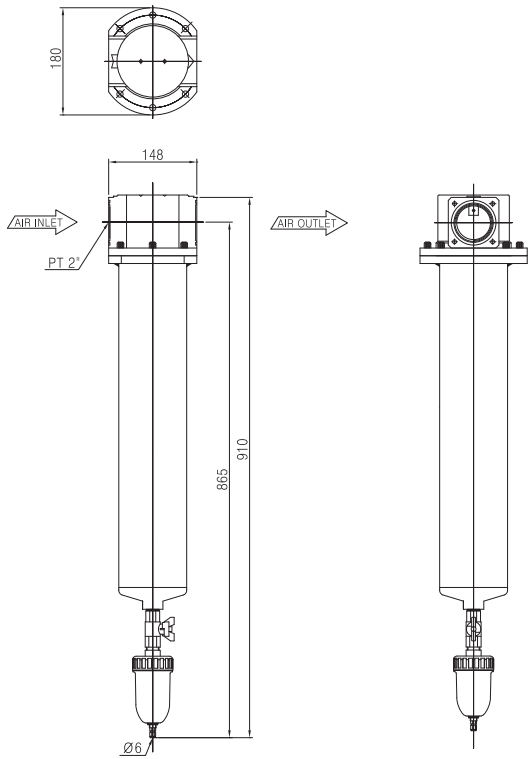

Model	CAPACITY(Nm <sup>3</sup> /min)	FILTER ELEMENT
370	29	MAIN ELEMENT(20u)
320	25	PRE ELEMENT(3u)
310	22	LINE ELEMENT(1u)
130	14	COALESCENT ELEMENT(0.01u)
150	14	ADSORBENT ELEMENT(0.01ppm)

## Outside Views of TXF 65A-370, 320, 310, 130, and 150

AIR FILTER 370,320

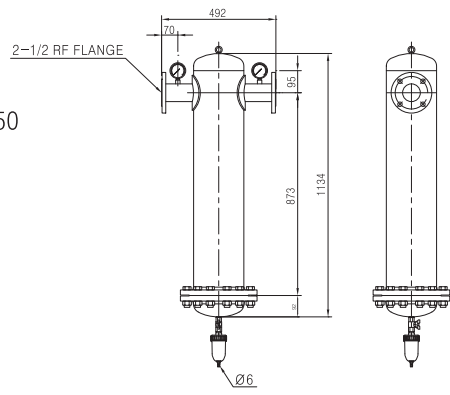
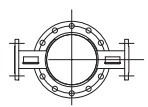
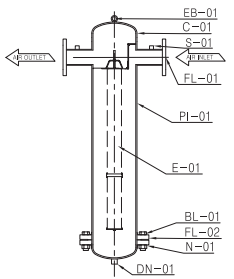

Model	CAPACITY(Nm <sup>3</sup> /min)	FILTER ELEMENT
70	58.0	MAIN ELEMENT(20u)
320	50.0	PRE ELEMENT(3u)
310	48.0	LINE ELEMENT(1u)
130	28.0	COALESCENT ELEMENT(0.01u)
150	28.0	ADSORBENT ELEMENT(0.01ppm)

AIR FILTER 310,130,150

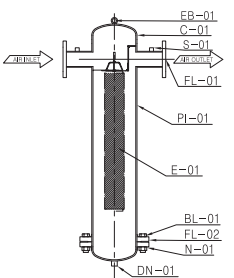

No.	Name of Part
EB-01	EYE BOLT
C-01	CAP
FL-01	KS10K RF FLANGE
S-01	PRESSURE GAUGE
PI-01	PIPE
E-01	ELEMENT
BL-01	BOLT
FL-02	KS10K SORF FLANGE
N-01	NUT
DN-01	DRAIN NOZZLE

## Series TXF

### Electronic Trap

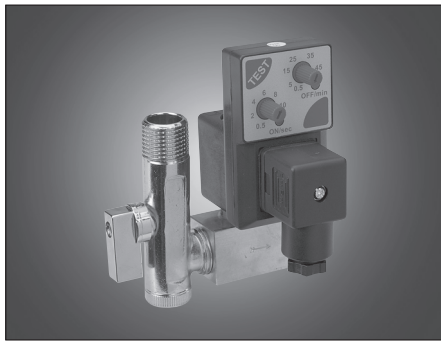

TDED-015

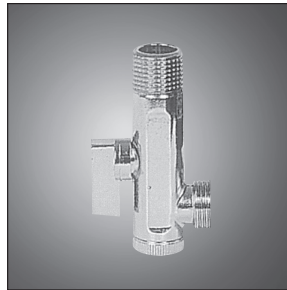

STRAINER VALVE / FILTER VALVE (OPTIONAL)

### Specifications

Model	TDED-015	TDED-006
Type	Direct acting Valve	
Maximum Service Pressure	1.57MPa (227.5psi)	3.9MPa (568.9psi)
Connection Caliber	PT 1/2"	PT 1/4"
Voltage	AC 1Ø 220V 50Hz / 60Hz	

#### ● Features

- Direct-acting solenoid valve with wide caliber (TDED)
- Protect it from dust and impurities, and prevent malfunctions with the application of Filter Valve (Strainer Valve).
- Control operation and set the machine with the timer.

### AUTO DRAIN TRAP



TDAD-125



TDAD-300

### FLOAT



TD-12

### Differential Pressure Gauge



TPG-15

### Specifications

MODEL	TDAD-125	TDAD-300	TD-12	TDDPG-15
Service Pressure	0.15~0.97MPa(1.5 - 9.9Kgf/cm <sup>2</sup> )			
Maximum Service Pressure	9.9~13Kgf/cm <sup>2</sup>	9.9Kgf/cm <sup>2</sup>	16Kgf/cm <sup>2</sup>	-
Service Temperature	60℃ ↓			
Connection Caliber	PT1/2"	M30	Drain Connection 1/8 NPT"	1/8" / 1/4"
Application	Filter(20A-150A) · TANK		Filter, Trap	Filter

#### ● Features

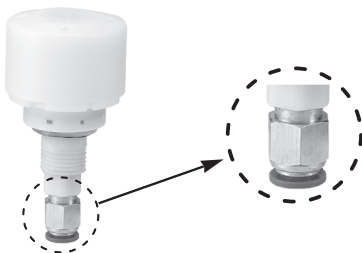

- Maintenance cost is low since power is not necessary.
- Float is mounted in the body, and the portion is automatically discharged to the outside, if a certain amount of condensed water is filled.