

Series SC

Compact Fittings

Compact One-Touch Fittings



Features

- ONE ACTION INSERTS THE TUBE TO EASY CONNECTION AND RELEASE
- VOLUME AND OD ARE SMALLER THAN THE REGULAR TYPE, BUT SAME FLUX IS OBTAINED
- TREATED WITH ELECTROLESS NICKEL COATING ON THE SURFACE FOR EXCELLENT TOLERANCE TO CORROSION
- OVAL SLEEVE IS DESIGNED TO ALLOW EASY RELEASE IN LIMITED SPACE
- THE SCREW SECTION HAS O-RINGS, OR IS SEALANT COATED
- MINIATURIZED FITTING FOR SMALL DEVICES AND PIPING IN LIMITED SPACES

How to Order

SC L 04 - 01 S



1 Model

2 Applicable Tube O. D.

04 : Ø4
06 : Ø6

3 Port Size

M5 : M5 x 0.8
01 : R(c) 1/8

4 Sealant Screw

S : Sealant

Structural Diagram

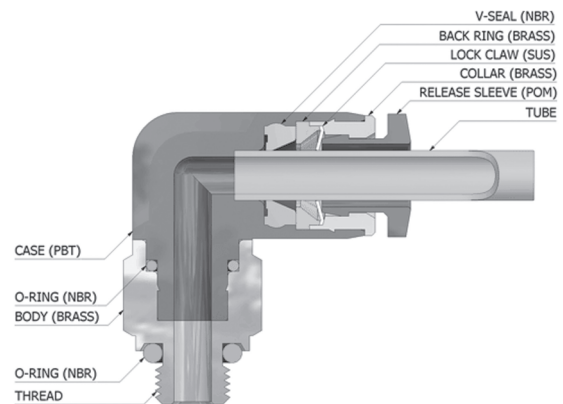

Standard Specifications

Fluid Type	Air
Max. Operating Pressure	0~150psi (0~9.9kgf/cm ²)
Ambient and Fluid Temperature	0~60 °C
Applicable Tube O.D	Ø4, Ø6

Series SC

SCH



METRIC-BSPT(R)

MODEL	∅D (Tube Size)	T (Tube Size)	∅P	L	A	B	H (Hex.)	X	Y	Weight (g)
SCH 04-M5	4	M5×0.8	8.0	17.1	3.6	11.7	8	10.4	8.2	4.0
SCH 04-01S		R 1/8		16.7	8.0		10			6.0
SCH 06-M5	6	M5×0.8	10.0	18.5	3.6	12.8	10	12.4	10.2	5.0
SCH 06-01S		R 1/8		19.0	8.0		10			7.0

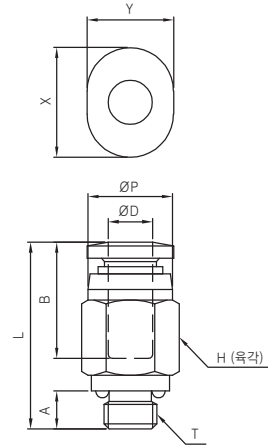

- SN
- SP2000
- SP4000
- SQ
- SC**
- SP
- SHF · SHS
- DC
- SQ2
- ST
- SF

SCH-A



METRIC-BSPT(R)

MODEL	∅D (Tube Size)	T (Tube Size)	∅P	L	A	B	H (Hex.)	X	Y	Weight (g)
SCH 04-M5A	4	M5×0.8	8.0	16.9	3.6	11.7	2.5	10.4	8.2	4.0
SCH 04-01SA		R 1/8		15.7	8.0		3.0			5.0
SCH 06-M5A	6	M5×0.8	10.0	18.5	3.6	12.8	2.5	12.4	10.2	5.0
SCH 06-01SA		R 1/8		19.0	8.0		4.0			6.0

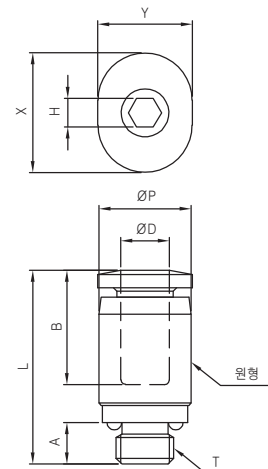

SCL



METRIC-BSPT(R)

MODEL	∅D (Tube Size)	T (Tube Size)	∅P	L	E	A	B	H (Hex.)	X	Y	Weight (g)
SCL 04-M5	4	M5×0.8	8.7	20.2	18.6	3.6	11.8	8	10.4	8.2	4.0
SCL 04-01S		R 1/8		20.7	8.0	10	7.0				
SCL 06-M5	6	M5×0.8	10.8	22.3	19.6	3.6	12.9	8	12.4	10.2	4.0
SCL 06-01S		R 1/8		22.8	8.0	10	7.0				

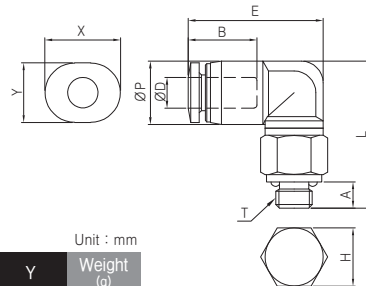

Series SC

SCH-00



METRIC-BSPT(R)

MODEL	ØD (Tube Size)	ØP	E	B	X	Y	Weight (g)
SCH 04-00	4	8.4	24.5	11.8	10.4	8.2	3.0
SCH 06-00	6	10.6	26.8	26.8	12.4	10.2	3.0

Unit : mm

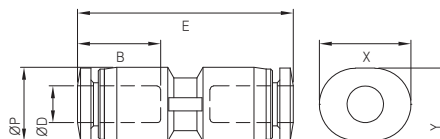

SCL-00



METRIC-BSPT(R)

MODEL	ØD (Tube Size)	ØP	L	E	ØC	B	X	Y	Weight (g)
SCL 04-00	4	8.4	18.7	18.7	3.2	11.8	10.4	8.2	3.0
SCL 06-00	6	10.6	21.9	21.9	3.2	12.9	12.4	10.2	3.0

Unit : mm

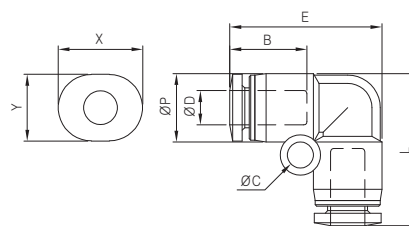

SCT-00



METRIC-BSPT(R)

MODEL	ØD (Tube Size)	ØP	L	E	ØC	B	M1	M2	X	Y	Weight (g)
SCT 04-00	4	8.4	18.7	28.9	3.2	11.8	5.8	11.6	10.4	8.2	3.0
SCT 06-00	6	10.6	21.9	33.2	3.2	12.9	6.9	13.8	12.4	10.2	6.0

Unit : mm

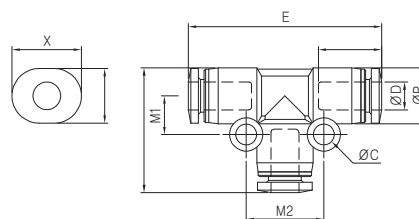

Series SC

SCH-R

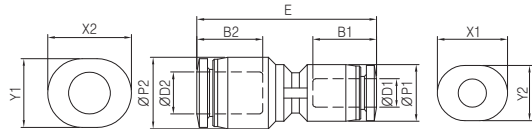

METRIC-BSPT(R)

MODEL	ØD1 (Tube Size)	ØD2 (Tube Size)	ØP1	ØP2	E	B1	B2	X1	Y1	X2	Y2	Weight (g)
SCH 04-06	4	6	8.4	10.6	26.6	11.8	12.9	10.4	8.2	12.4	10.2	3.0

Unit : mm

- SN
- SP2000
- SP4000
- SQ
- SC**
- SP
- SHF · SHS
- DC
- SQ2
- ST
- SF

SCU-00



METRIC-BSPT(R)

MODEL	ØD (Tube Size)	ØP	L	E	ØC	B	X	Y	Weight (g)
SCU 04-00	4	8.7	28.0	17.4	3.2	11.8	10.4	8.2	5.0
SCU 06-00	6	10.8	30.8	21.6	3.2	12.9	12.4	10.2	6.0

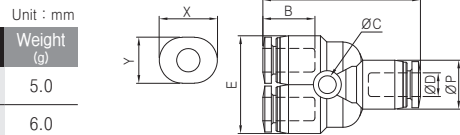

SCU-R

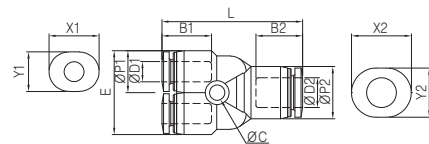

METRIC-BSPT(R)

MODEL	ØD1 (Tube Size)	ØD2 (Tube Size)	ØP1	ØP2	L	E	ØC	B1	B2	X1	Y1	X2	Y2	Weight (g)
SCU 04-06	4	6	8.7	10.8	29.1	17.4	3.2	11.8	12.9	10.4	8.2	12.4	10.2	5.0

Unit : mm

Series SC

SCT

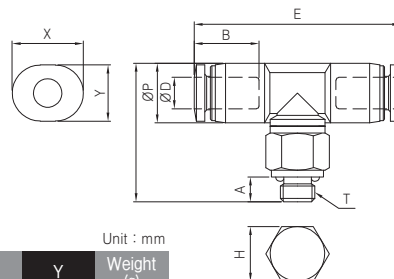

METRIC-BSPT(R)

MODEL	ØD (Tube Size)	T (Tube Size)	ØP	L	E	A	B	H (Hex.)	X	Y	Weight (g)
SCT 04-M5	4	M5×0.8	8.7	20.2	30.1	3.6	11.8	8	10.4	8.2	5.0
SCT 04-01S		R 1/8		20.7		8.0		10			7.0
SCT 06-M5	6	M5×0.8	10.8	22.3	32.2	3.6	12.9	8	12.4	10.2	7.0
SCT 06-01S		R 1/8		22.8		8.0		10			9.0

Unit : mm

SCY

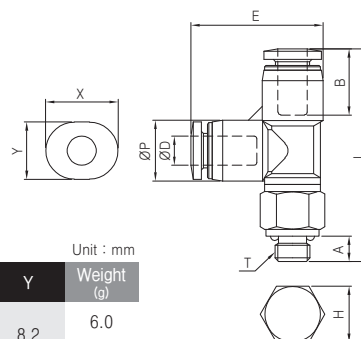

METRIC-BSPT(R)

MODEL	ØD (Tube Size)	T (Tube Size)	ØP	L	E	A	B	H (Hex.)	X	Y	Weight (g)
SCY 04-M5	4	M5×0.8	8.7	30.4	18.9	3.6	11.8	8	10.4	8.2	6.0
SCY 04-01S		R 1/8		30.9		8.0		10			9.0
SCY 06-M5	6	M5×0.8	10.8	33.5	22.0	3.6	12.9	8	12.4	10.2	7.0
SCY 06-01S		R 1/8		34.0		8.0		10			10.0

Unit : mm

SCE-00

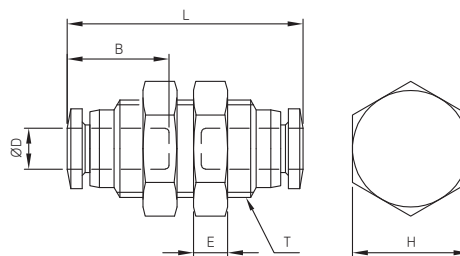

METRIC-BSPT(R)

MODEL	ØD (Tube Size)	ØD2 (Tube Size)	L	E	B	H (Hex.)	Weight (g)
SCE 04-00	4	M10×1.0	24.3	3.5	11.7	12	10.0
SCE 06-00	6	M12×1.0	27.1	4	12.8	14	14.0

Unit : mm

Series SC

SCJ

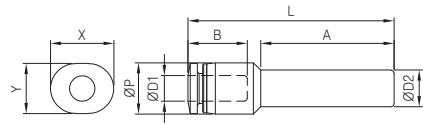

METRIC-BSPT(R)

MODEL	ØD1 (Tube Size)	ØD2 (Tube Size)	ØP	L	A	B	X	Y	Weight (g)
SCJ 04-06	4	6	8.4	33.7	21.8	11.8	10.4	8.2	3.0

Unit : mm

- SN
- SP2000
- SP4000
- SQ
- SC**
- SP
- SHF · SHS
- DC
- SQ2
- ST
- SF

SCF

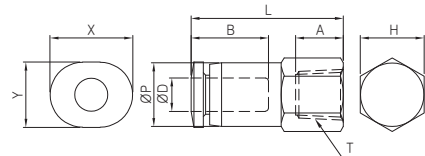

METRIC-BSPT(R)

MODEL	ØD (Tube Size)	T (Tube Size)	ØP	L	A	B	H (Hex.)	X	Y	Weight (g)
SCF 04-M5	4	M5×0.8	8.0	19.2	6.0	11.7	8	10.4	8.2	4.0
SCF 04-01S		Rc 1/8		22.7	8.5		12			5.0
SCF 06-M5	6	M5×0.8	10.0	19.8	6.0	12.8	10	12.4	10.2	5.0
SCF 06-01S		Rc 1/8		23.8	8.5		12			6.0

Unit : mm