

# PL1 Series

## Lubricator M5



PL1

### Specifications

Fluid	Pressed air
Max. operating pressure (MPa)	10 bar (1.0MPa)
Proof pressure (MPa)	15 bar (1.5MPa)
Ambient and fluid temperature (°C)	-5 ~ 60 (anti-freezing)
Recommended lubricant	ISO VG32 (Class 1 turbine oil)
Bowl material	Polycarbonate (option : ALDC)

### Symbol

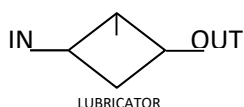

### How to order

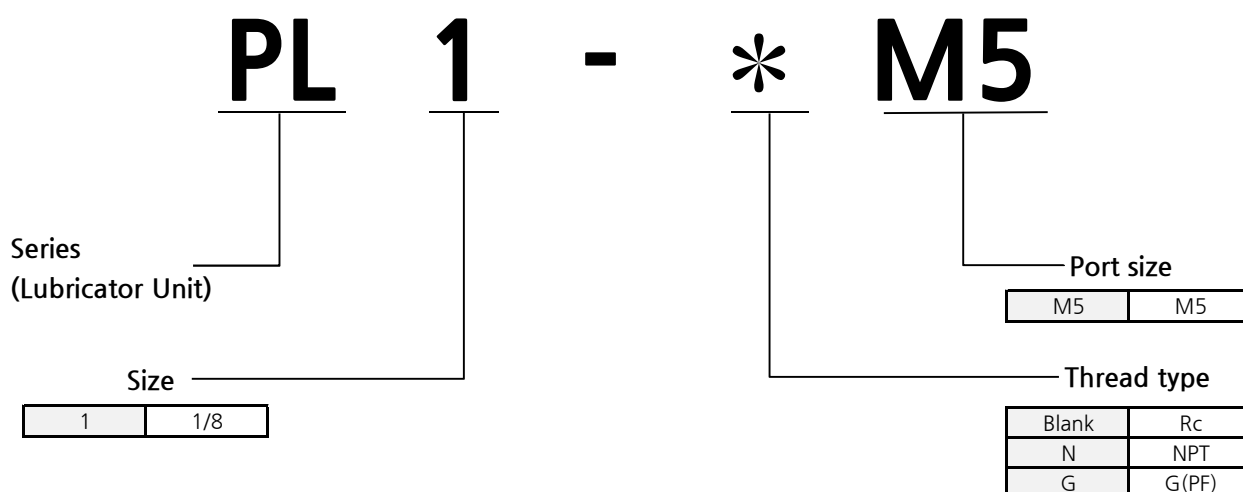

# PL1 Series

## Structure

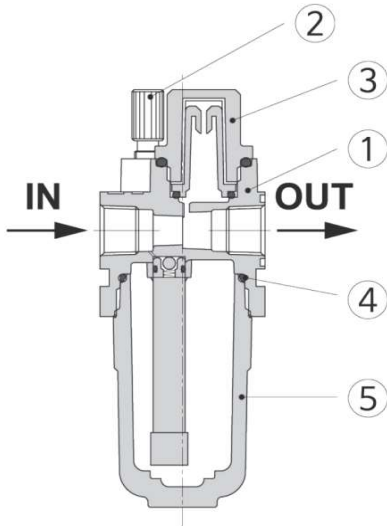

## Main Parts List

No.	Description	Material
①	Body	Zinc die casting
②	Oil Cap	Nylon
③	Throttle Screw	Bs
⑤	Bowl Ass'y	PC

## Supplementary Parts List

No.	Description	Material	Part no.
			PL1
④	O-ring	NBR	S22

## Dimensions

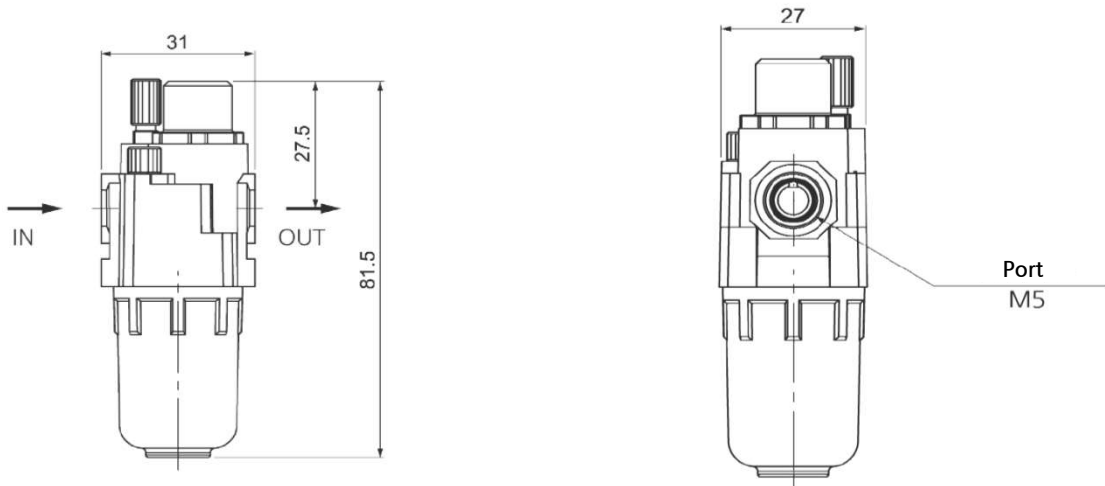

## Flow Characteristics

