

Series TAD-5 ~ TAD-800

Features of Refrigerated Air Dryer

TXF

TAD



- EXCELLENT MOISTURE REMOVAL THROUGH FORCED CONDENSATION BY REFRIGERANT GAS.
- COOLING DEVICE NECESSARY FOR STABLE SYSTEM CONSTRUCTION.
- CONVENIENT INSPECTION OF OPERATION DUE TO A CONSTRUCTION OF GRAPHIC CONTROL PANEL, ON/OFF SWITCH, ON/OFF LAMP, REFRIGERANT GAUGE, AND AIR GAUGE.

How to Order

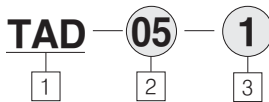

① Refrigerated Air Dryer (TPC Air Dryer)

② Standard Size

Sign	Applied Air Compressor (HP)
5	5
7	7
10	10
15	15
20	20
30	30
50	50
75	75
100	100
150	150
200	200
250	250
300	300
400	400
500	500
600	600
800	800

③ Rated Power

1	AC220V, 1Ø, 60Hz	TAD-5~TAD-100
2	AC220V, 3Ø, 60Hz	TAD-150~TAD-800
3	AC380V, 3Ø, 60Hz	
4	AC440V, 3Ø, 60Hz	

Series TAD-5 ~ TAD-800

Pressure and Temperature Conversion Multiplier Table

Inlet Pressure(kgf/cm ²)	3	4	5	6	7	8	9	10	11	12	13	14	15
Conversion Factor(C1)	0.74	0.84	0.91	0.96	1.00	1.04	1.06	1.09	1.11	1.12	1.14	1.15	1.17

Processing Capacity Setting Method(FA)

$$FA = \text{Processing Flow} \times C1 \times C2 \times C3$$

Inlet Temp-(°C)	30	35	38	40	43
Conversion Factor(C3)	1.48	1.28	1.1	1.0	0.91

Inlet Temperature(°C)	30	35	38	40	43	45	50	55	60
Conversion Factor(C3)	1.32	1.15	1.00	0.92	0.83	0.78	0.65	0.52	0.39

SPECIFICATIONS(Air Cooling Type)

MODEL	TAD-5	TAD-7	TAD-10	TAD-15	TAD-20	TAD-30	TAD-50	TAD-75	TAD-100	TAD-150	TAD-200	TAD-250	TAD-300	TAD-400	TAD-500	TAD-600	TAD-800	
Connection Caliber (Inch)	3/4"(S)				1"(S)	2"(S)	2"(S)	3"(F)			4"(F)			6"(F)		8"(F)		
Flow Capacity(m ³ /min)	60Hz	0.62	0.97	1.35	1.96	2.6	3.9	7.2	11.1	14.6	21.85	31.32	40.13	47.56	59.47	73.92	89.56	112.47
	50Hz	0.57	0.89	1.23	1.8	2.4	3.5	6.6	10.5	13.3	20.0	28.6	36.6	43.5	54.3	67.5	81.8	102.7
Refrigerant Gas (Freon Gas)	R-134a						R22											
Dew Point	1.7°C~4°C																	
Maximum Pressure	0.97MPa(9.9kg/cm ²)																	
Fluid	Compressed Air																	
Permissible Inlet Temperature	40°C																	
Ambient Temperature	1.7°C~40°C																	
Condenser	AIR COOLED TYPE																	
Rated Power	Voltage (V)	AC 220V 1Ø 60Hz									AC 220V/380V/440V 3Ø 60Hz							
	Current (A)	1.14	1.14	2.5	3.5	5.1	5.1	6	10	12.5	12.2	17	17	17	26	37	37	43.1
	Power Consumption(kw)	0.2	0.2	0.4	0.6	0.9	0.9	1.0	1.9	2.8	3.8	5.2	5.2	5.6	12.2	12.2	13.8	
Weight	40	40	40	45	84	86	117	170	196	325	380	468	660	790	1560	1700	1780	
Dimension W×L×H	310×575×535			310×670×560		320×700×670		411×1020×940		411×1030×1030		500×1500×1450		650×1750×1520		700×1800×1570		2500×1250×2500

- As standard R22 (Freon) is used for refrigerant gas, R22 or 134a can be produced to order for refrigerant gas, depending on models.
- Air processing capacity factor is based on Inlet Pressure 0.7 MPa (7.0 kgf/cm²), Inlet Temperature 40 °C, Ambient Temperature 38 °C, and Operation Dew Point 4 °C.
- Model: Electronic trap (Direct-acting type) is basically attached to Model TAD-20 or higher for a complete discharge of condensate up to a very small amount.
- Rated-power products with special specifications can be produced to order.
- Air processing capacity factor is based on Inlet Pressure 7.0 kgf/cm², Inlet Temperature 38 °C, and Ambient Temperature 4 °C.
- Above products may be changed without prior notice due to technology development.

Functions of Air Dryer

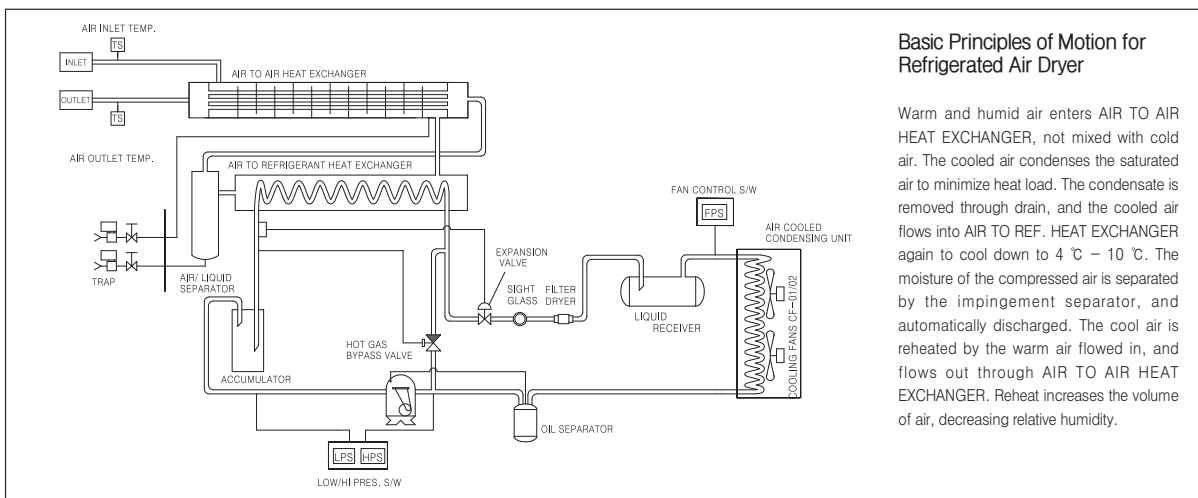

Basic Principles of Motion for Refrigerated Air Dryer

Warm and humid air enters AIR TO AIR HEAT EXCHANGER, not mixed with cold air. The cooled air condenses the saturated air to minimize heat load. The condensate is removed through drain, and the cooled air flows into AIR TO REF. HEAT EXCHANGER again to cool down to 4 °C - 10 °C. The moisture of the compressed air is separated by the impingement separator, and automatically discharged. The cool air is reheated by the warm air flowed in, and flows out through AIR TO AIR HEAT EXCHANGER. Reheat increases the volume of air, decreasing relative humidity.

Series TAD-5 ~ TAD-800

Considerations for Installation

Please read carefully the following before installing Air Dryer for extended use without breakdown.

- 1) Appropriate Places for Installation of AIR DRYER
 - ① Flat place
 - ② Place without acidic or alkaline substances
 - ③ Place without combustible gas
 - ④ Place easy for AIR piping and electric wiring
 - ⑤ Place without dust and vibration
 - ⑥ Place easy to check and repair the product
 - ⑦ Place with appropriate ambient temperature in winter and summer (1.7℃ - 40℃)
- 2) Precautions for Installation
 - ① A minimum space of 1.5 M or more for the product shall be secured for sufficient fresh air and easy maintenance.
 - ② The strength of the base for installation shall be considered before installation, and foundation work shall be done, if the ground is unstable.

※ Places to Particularly Avoid

Slope, place with severe vibration, place exposed to direct sunlight, heated place, place exposed to rains, place with much dust and pollutants, place with bad ventilation, and place with standard service temperature (1.7℃ - 40℃) unavailable.

- ① If the temperature falls below 2℃, the inside of DRAIN TRAP may be frozen.
- ② If the temperature rises above 40℃, AIR DRYER may stop working.

How to Lay Pipes

The assembly of pipes shall be adjusted, using tools such as a wrench, and piping shall be provided for sections with defective screws to prevent air leakage. If not fixed, the case may be damaged.

※ Caution

Be sure to close BY-PASS VALVE while in use.

- ① The inlet and outlet of AIR DRYER shall be correctly connected in piping.
- ② Be careful that the weight of piping is not loaded on the body.
- ③ Make sure that the vibration of AIR COMPRESSOR is not transmitted to DRYER, and avoid vertical piping.
- ④ Install a BY-PASS pipe between inlet and outlet of AIR DRYER.
- ⑤ For convenience purpose, union or flange shall be applied to the inlet and outlet of DRYER for connection.
- ⑥ Zinc-plated pipe shall be used.
- ⑦ The condensed water from the drain outlet shall be discharged to the outside through a separate drainpipe.

※ Note

Since if the drainpipe is vertical or extended, pressure is produced in the pipe, the condensed water may not be discharged.

Method for Daily Operation

- 1) Press the operation switch.
- 2) The RUN lamp is lighted, and the refrigeration compressor is operated.
- 3) Check if the needle on the refrigerant pressure gauge indicates 2.5 - 3.5 kgf/cm² (R-134c) ~ 3.5 - 5.5 kgf/cm² (R-22).
- 4) Allow compressor air to flow in 5 minutes after operation.

How to Wire

① Electric Wire

The capacity of power cable is as follows.

Form	Model	TAD-5~ TAD-100	TAD-100	TAD-150~ TAD-250	TAD-300~ TAD-400
Rated Power		1PH		3PH	
		AC 220V 50Hz/60Hz		AC 220V/380V/440V 50Hz/60Hz	
Power Cable(mm ²)		2.0 or more		3.5 or more	5.5 or more

- ② A single-phase circuit breaker for wiring shall be installed for overload protection and to prevent an electric shock due to leakage before installing AIR DRYER.
- ③ Be sure to install Ground Cord. (Third-class grounding work is required.)
- ④ DRYER shall be operated within ±5% of the standard voltage to meet the rated power.

How to Operate

1) Start-up

After installation is completed, start-up shall be provided after thoroughly checking the following.

☞ Checkpoints

- ① Aren't there any problems in the installed air-pressure pipe and line?
- ② Is the valve of BY-PASS pipe closed?
- ③ Is the valve of Drain Discharge pipe opened?

☞ Checkpoints for Power

- ① Is voltage normal?
- ② Isn't the capacity of fuse circuit breaker for wiring different from the designated.

2) How to Operate

Press the ON button of the power switch.

☞ If the power lamp is lighted, operation starts. If the needle on the refrigerant pressure gauge indicates 2.5~3.5kgf/cm²(R-134c)~3.5~5.5kgf/cm²(R-22) in one minute after the refrigeration compressor has started to operate, it means a normal state.

☞ In 5 minutes after operation, compressed air flows in slowly while the air compressor is in operation. (Be careful that pressure is not loaded on AIR DRYER at once.)

※ Note

To restart after stop, an interval of 5 minutes or more is required.

Safety Device

For safe use, it has a safety device mounted. If the safety device functions, AIR DRYER stops automatically.

1) Electric Circuit: MOTOR PROTECTOR

If over current flows in Refrigeration Compressor, MOTOR PROTECTOR works to stop AIR DRYER.

2) How to Release

- ① Remove the cause of stop (see Causes of Failure and Measures.)
- ② Press the START button for operation.

TXF

TAD

Series TAD-5 ~ TAD-800

Daily Checks and Cleaning

1) Daily Checks

- ① Check the Auto Drain Trap.
- ② Check if the timer of Electronic Trap has been correctly set (ON 2 seconds, OFF 2 minutes).
- ③ Check if there are any air leaks.
- ④ Check if it works normally. (Check if water comes out.)
- ⑤ Check inlet temperature for compressed air and ambient temperature, and clean Condenser and After cooler for the removal of dust on a regular basis.

2) Cleaning

- ① Cleaning of Condenser
 - Clean the condenser on a regular basis, using a vacuum cleaner, a brush, or an air gun.
 - DRYER CASE shall have both sides disassembled one by one.
 - If dust is accumulated on the condenser, it is not only good for heat exchange, but also may stop the operation of AIR DRYER as Safety Device works, if severe.

※ Note

Be careful not to deform the fins of Condenser while cleaning.

② Cleaning of Auto Drain Trap (Solenoid Valve)

- Disassemble and clean the auto drain trap on a regular basis for a regular operation all the time.

Tips for Adjustment of Hot Gas Bypass Valve

- 1) Since the hot gas bypass valve has been adjusted when shipped, it shall be adjusted only if abnormalities are found. Loosen the nut of the valve, and adjust the valve with a driver, seeing the refrigerant pressure gauge, until the needle on the refrigerant pressure gauge is within the normal scope.

Pressure Scope of Refrigerant R-22

- Low Pressure : 0.4~0.45MPa(4~ 4.5kgf/cm²)
- High Pressure : 1.3~1.75MPa(13 ~ 20kgf/cm²)

Causes of Failure and Measures

If failure is suspected while using, please check the following.

Symptoms	Causes														Measures				
	Refrigerant leaks	Thermal Relay is defective	Bypass Valve is opened	Light from Lamp is blocked	Switch is defective	Power voltage is too low	Refrigeration Compressor is defective	Solenoid Valve is defective	Solenoid Valve has foreign substance	Solenoid Valve has been frozen	Air processing volume is too much	Cooling capacity has decreased	Hot Gas Bypass Valve is defective	Condenser is clogged		The ambient temperature is too high	Fan Motor is defective	Compressor Magnet is defective	Pressure Switch for fan control is defective
Even though the switch is turned ON, it does not operate.	Operation Lamp is OFF		○		○	○													
	Operation Lamp is ON						○										○		
Water and oil come out while the needle on the refrigerant pressure gauge indicates normal.			○					○	○	○	○								
The needle on the refrigerant pressure gauge indicates high pressure, and water and oil come out.							○	○	○	○	○	○	○	○	○	○			○
Condensed water is not discharged from the Auto Drain.								○	○	○									
The temperature of Air Outlet is equal to or higher than that of Air Inlet.	○		○				○				○		○						
The machine has stopped during operation.	○	○					○				○					○	○	○	○
High Pressure Alarm Lamp is lighted.	○														○	○	○	○	○
Over Current Alarm Lamp is lighted.		○					○										○	○	
	Check gas leak areas	Exchange	Close the Bypass Valve	Exchange	Exchange	Use Regulated Voltage	Exchange	Exchange	Disassemble and Clean	Set the ambient temperature to more than 20	Air processing volume shall be set at the normal	Check gas leakage and refrigerant amount	Exchange and Adjust	Clean	Lower the ambient temperature	Exchange	Exchange	Exchange	

Series TAD-5 ~ TAD-800

TXF
TAD

Outside Dimensions of TAD 5, 7 and 10

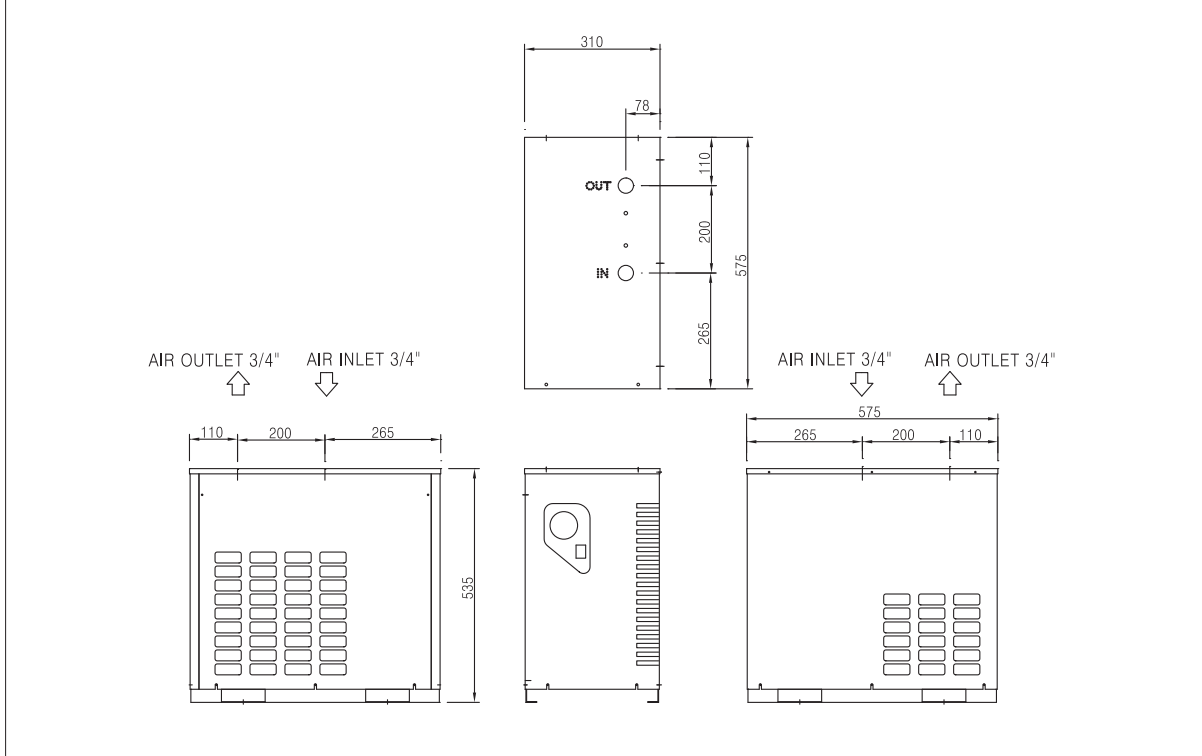

Outside Dimension of TAD 15

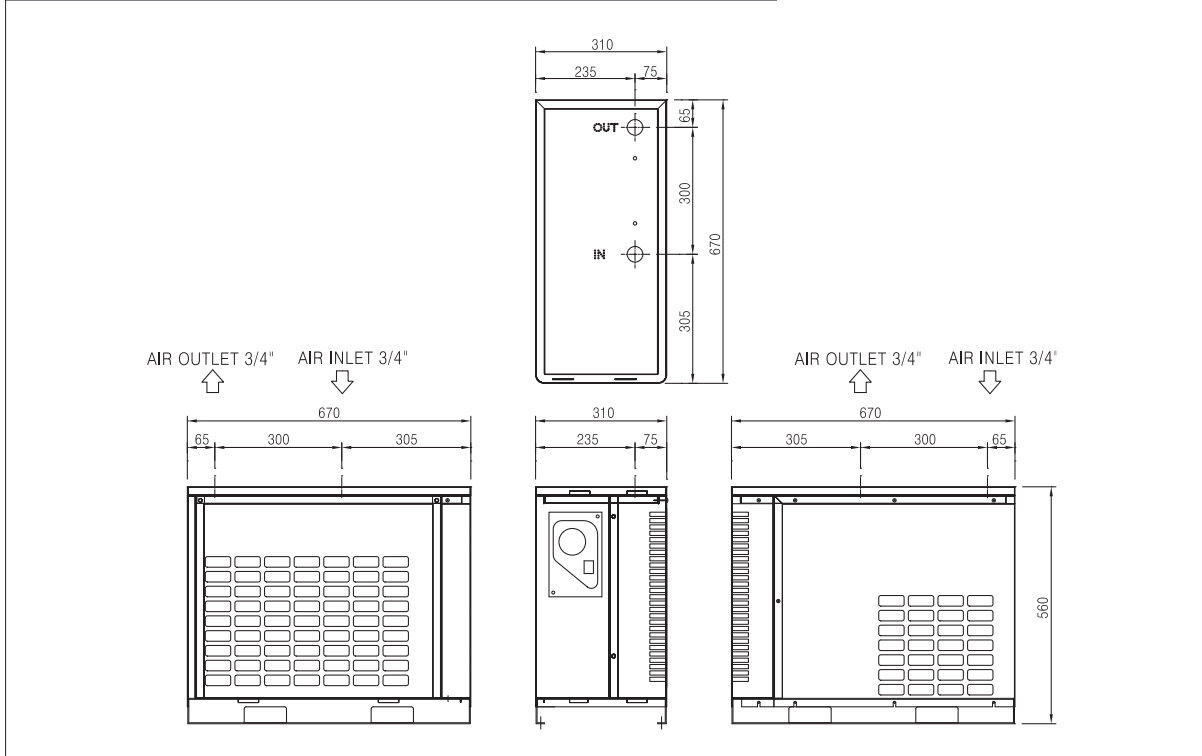

Series TAD-5 ~ TAD-800

Outside Dimensions of TAD 20 ~ 30

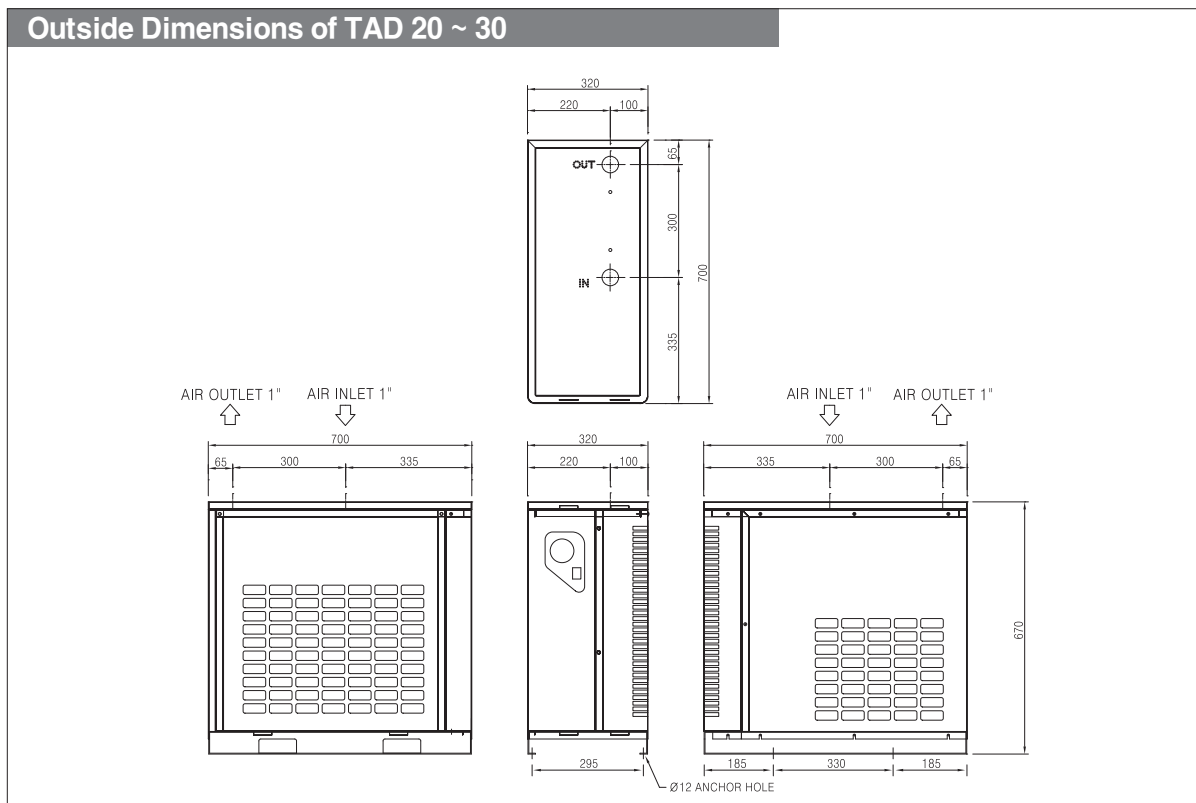

Outside Dimensions of TAD 50 ~ 75

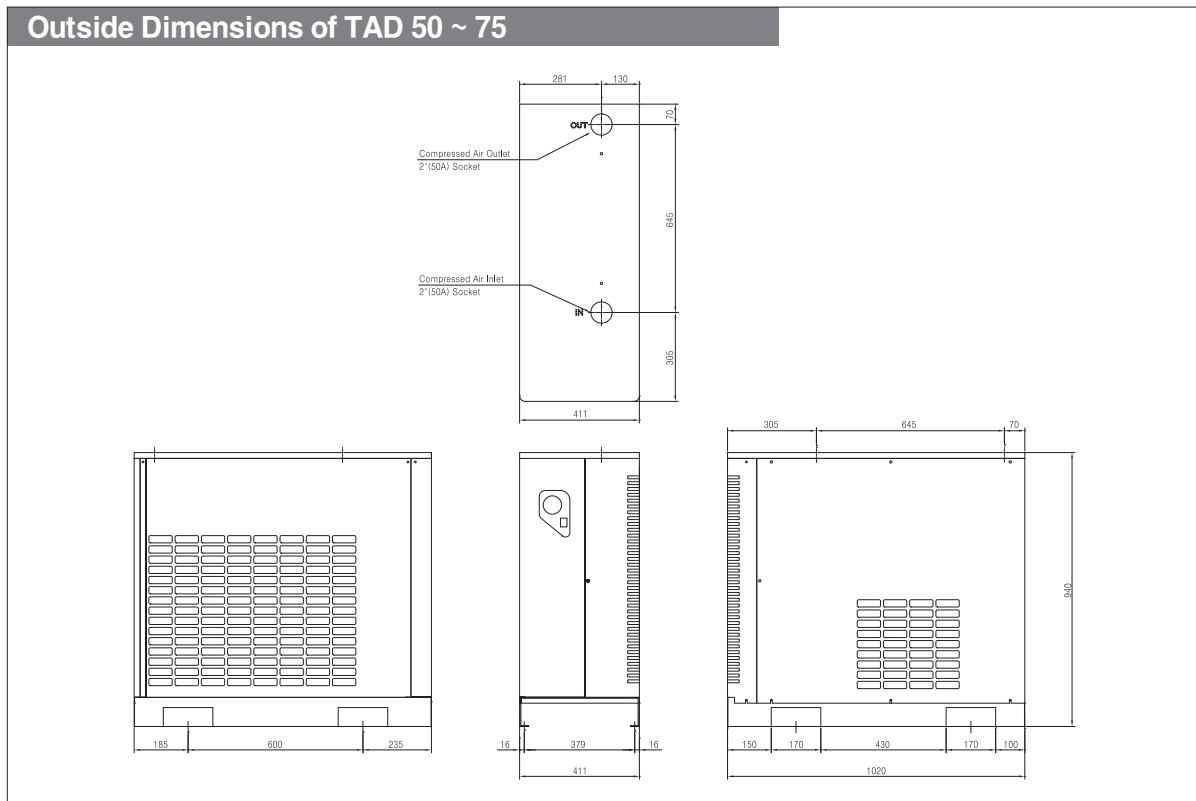

Series TAD-5 ~ TAD-800

TXF
TAD

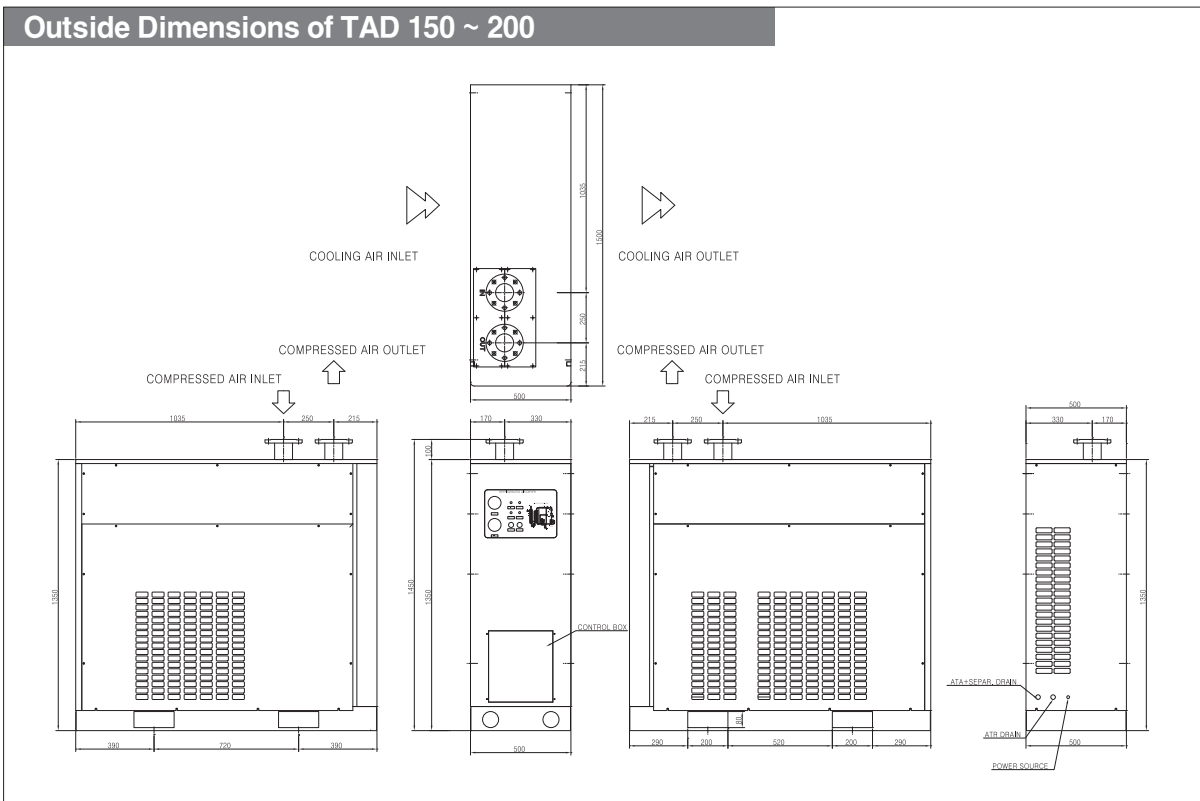
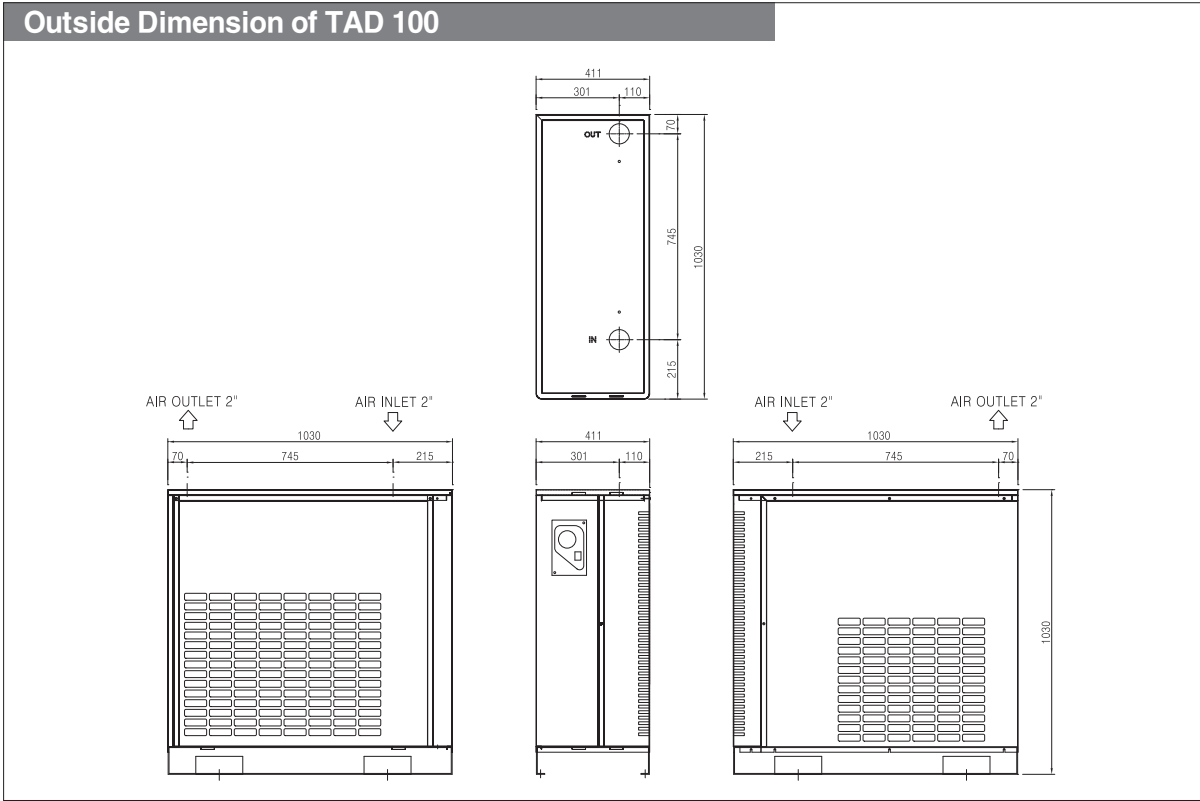

Series TAD

Outside Dimensions of TAD 250 ~ 300

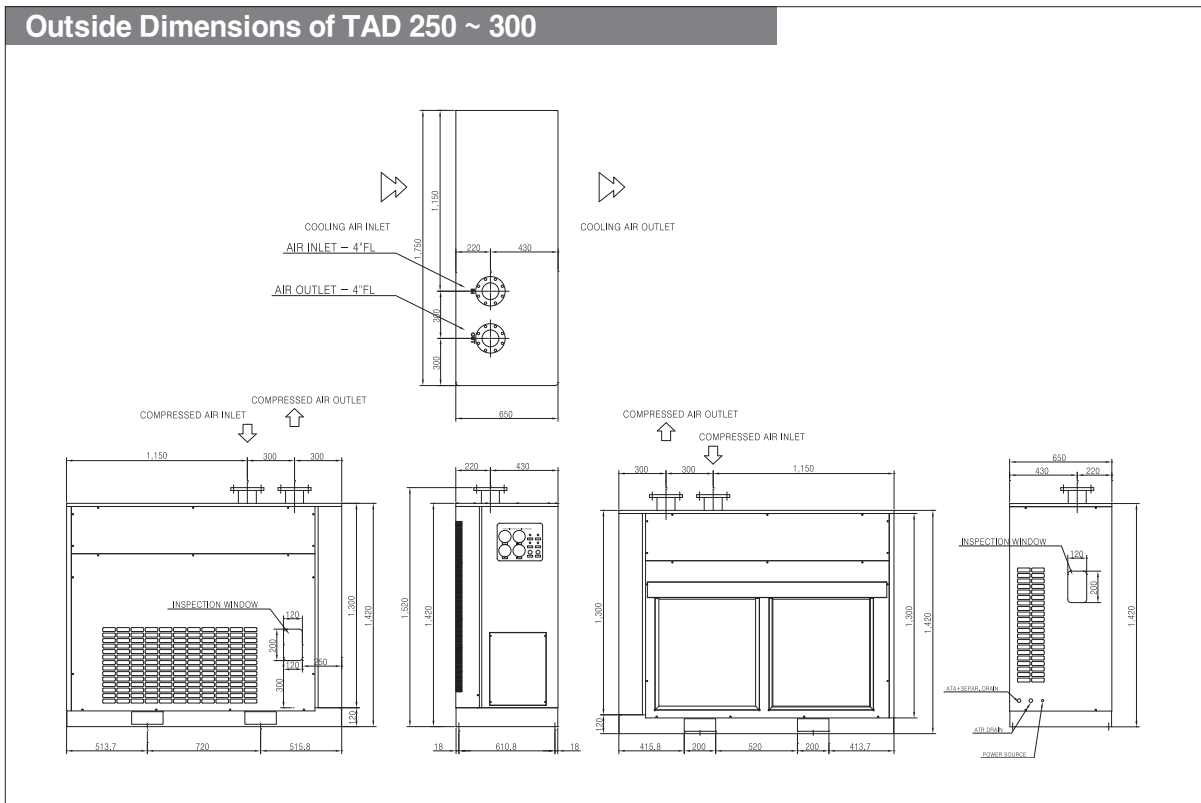

Outside Dimension of TAD 400

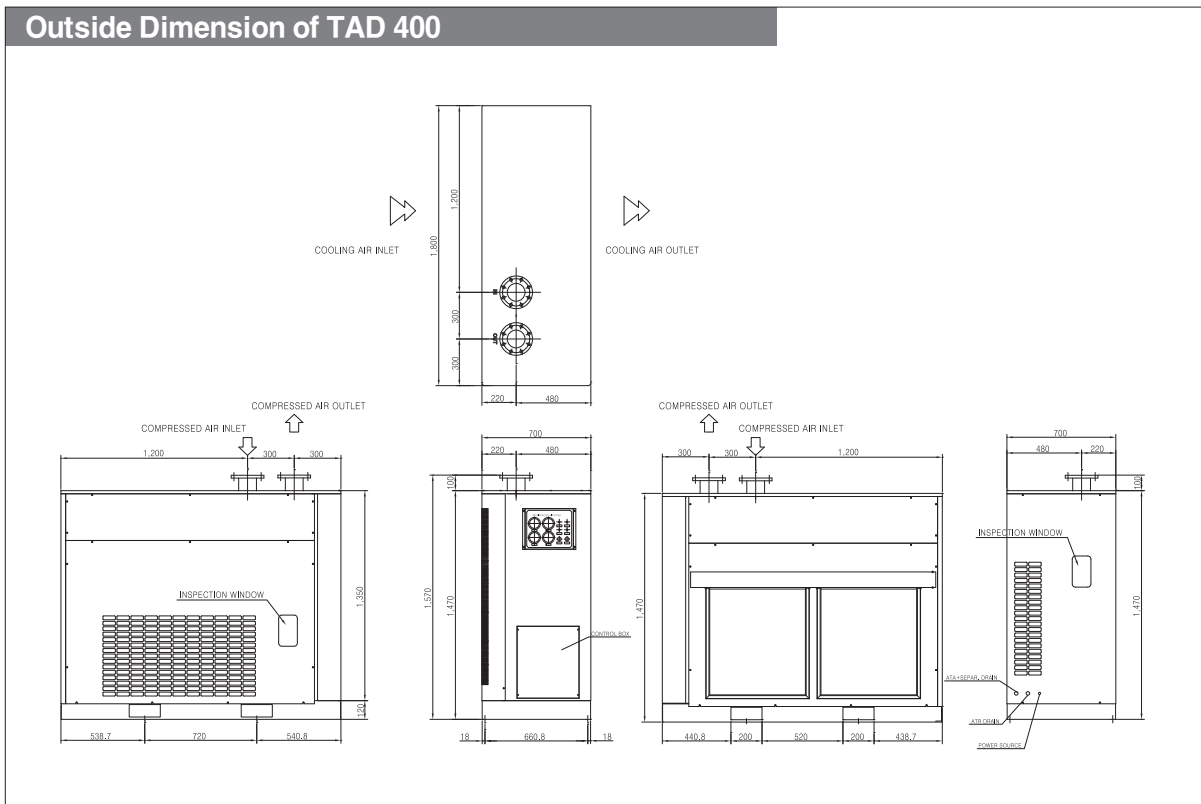

Series TAD

TXF
TAD

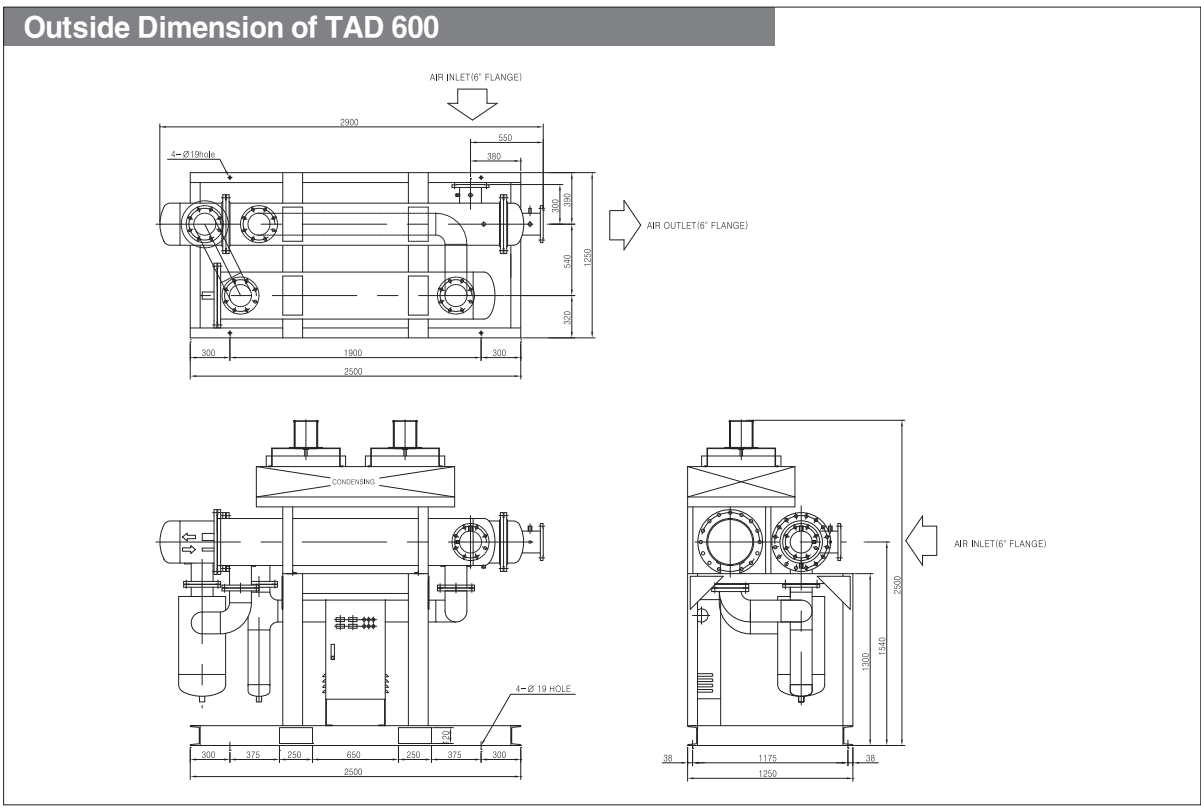
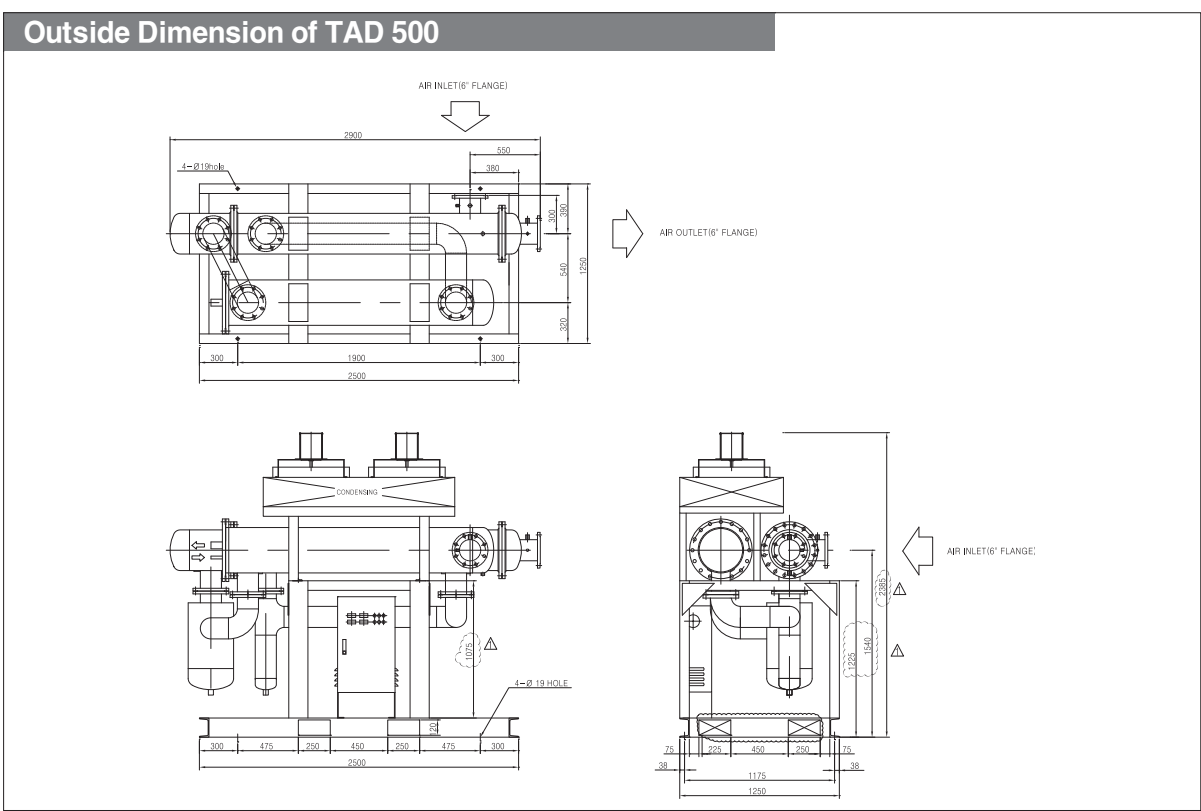

Series TAD

Outside Dimension of TAD 800

